



Vapormatt | Cougar Radial



The benefits of the Vapormatt Cougar Radial

- Automatic operation - wet blast and rinse
- Consistent and reproducible processing
- Ensures overall top surface cleaning with high penetration into bores and orifices
- Creates a fine surface finish - eliminating final hand finishing
- Rugged construction from non corrosive materials
- Dust free, fine surface cleaning and polishing



Vapormatt | Cougar Radial

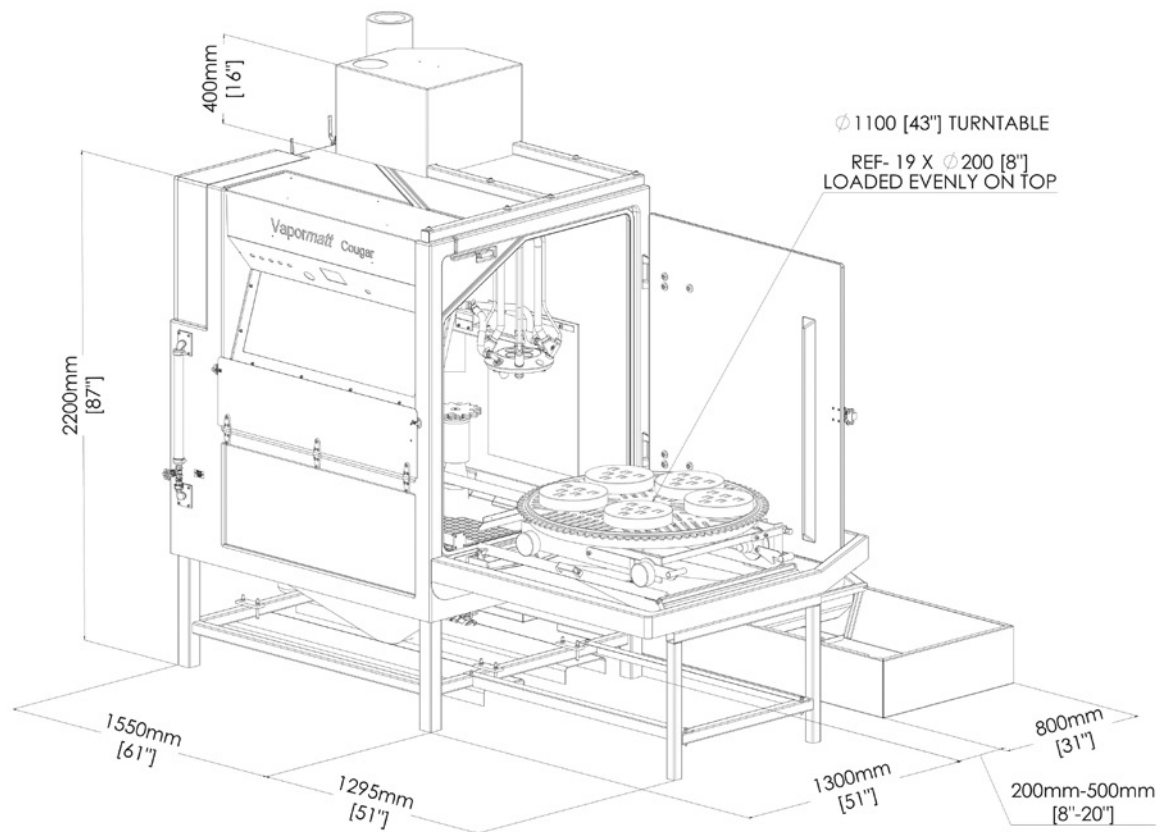

The Vapormatt Cougar Radial automatic machine provides an entry level solution for production facilities requiring automated wet blasting facilities.

Work pieces are loaded directly onto the diameter 43" / 1100 mm turntable.

During processing the turntable rotates whilst the 4 blast gun array traverses radially across the moving parts. This combination of movements combined with the inclined angles of the 4 separate blast streams ensures a high degree of penetration and consistent processing of even the most difficult to access critical surfaces.

The machine is programmed with a predefined sequence of gun array movements linked to the rotation of the turntable itself. Process duration can thus be varied by the simple control of the turntable speed.

Cleaning of both sides of components is facilitated by simply turning over the parts on the turntable and running the blast cycle for a second time.

Following blasting the sequence is repeated at high speed with the rinse nozzles operating alone and the slurry blasting guns turned off. This allows an initial component rinsing to be carried out.

Final rinsing is carried out by hand when unloading the cabinet.

A manual process station is also provided to allow immediate processing of individual "urgent" parts or to enable a touch up of areas needing only a small amount of additional processing.

The process is completely contained within the water tight processing enclosure. Machine access doors are safety interlocked and fluorescent lighting is included rated to IP65.

All pressurized conduits carrying abrasive slurry are contained within the main cabinet.

The processing enclosure has ventilation / air extraction via ducting to external atmosphere, with the option of an air extraction / filtration unit fitted to the roof of the machine. With this unit fitted, exhausted air can be returned to the workshop.

The unit can be specified for fully closed loop operation. Media filtration using a batch elutriation technique and an external liquid filtration system allows process debris and dirt removed from the component surfaces to be collected in a convenient manner to facilitate easier disposal via established in house waste streams.

Patents and new patent applications cover several of the unique features of the Vapormatt Cougar Radial automatic machine.

For further information contact:

Monarch Centre
Venture Way
Priorswood Industrial Estate
Taunton
Somerset
TA2 8DE
UK

t +44 (0) 1823 257976
f +44 (0) 1823 336446
e sales@vapormatt.com
w www.vapormatt.com
USA:
Rotec Tools Ltd.
info@rotectools.com
(845)621-9100



Vapormatt